

2

1

B

B

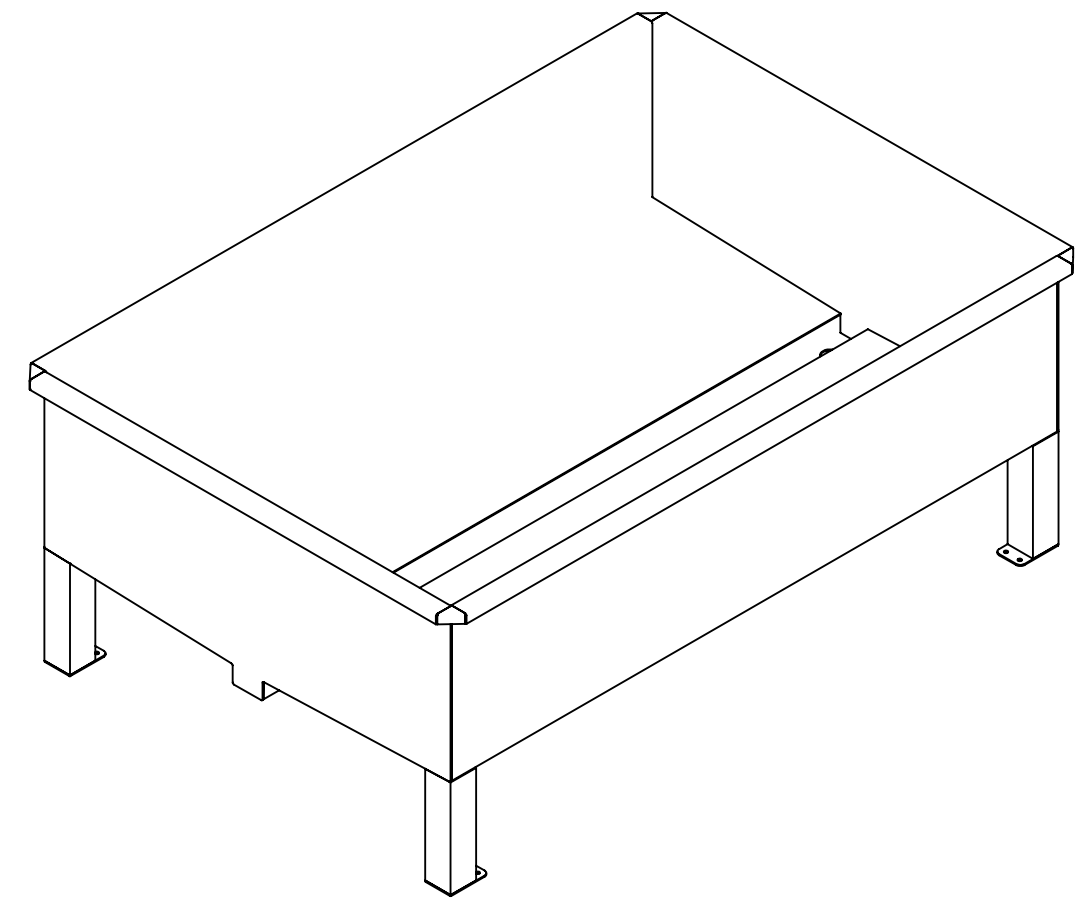
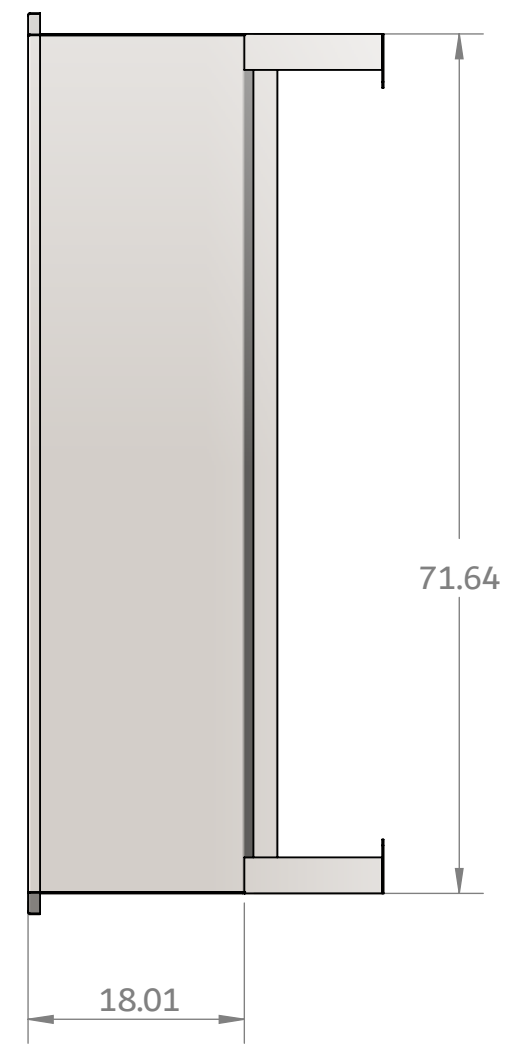
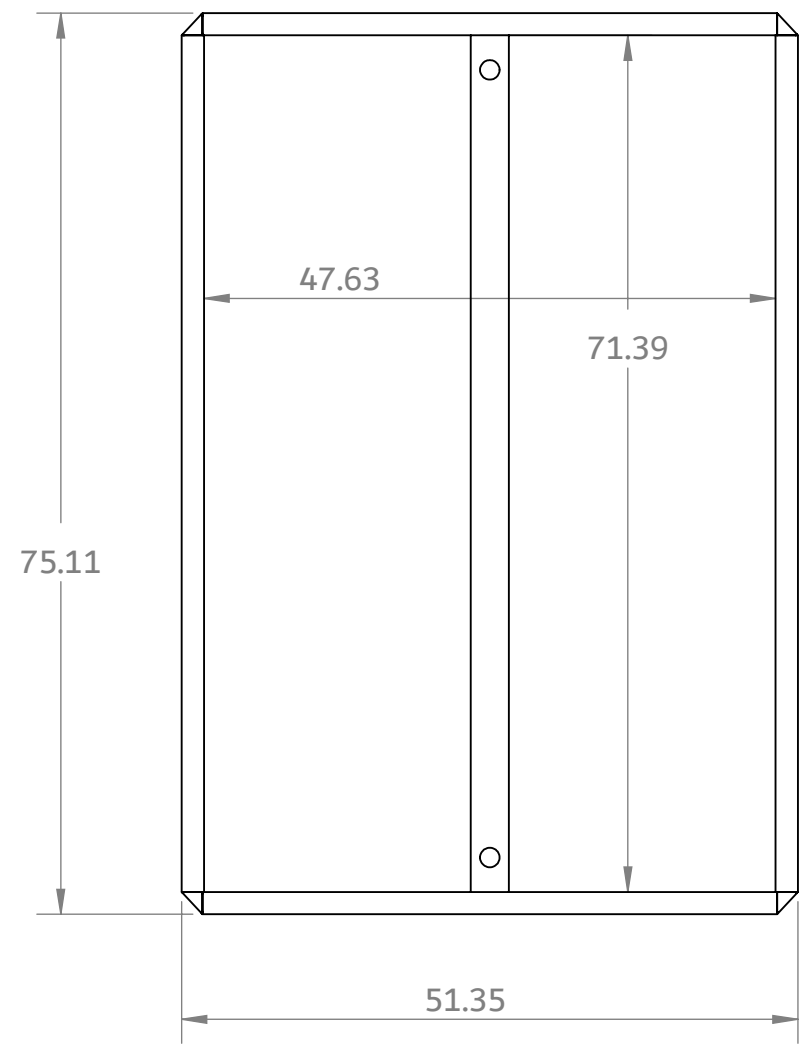

A

A

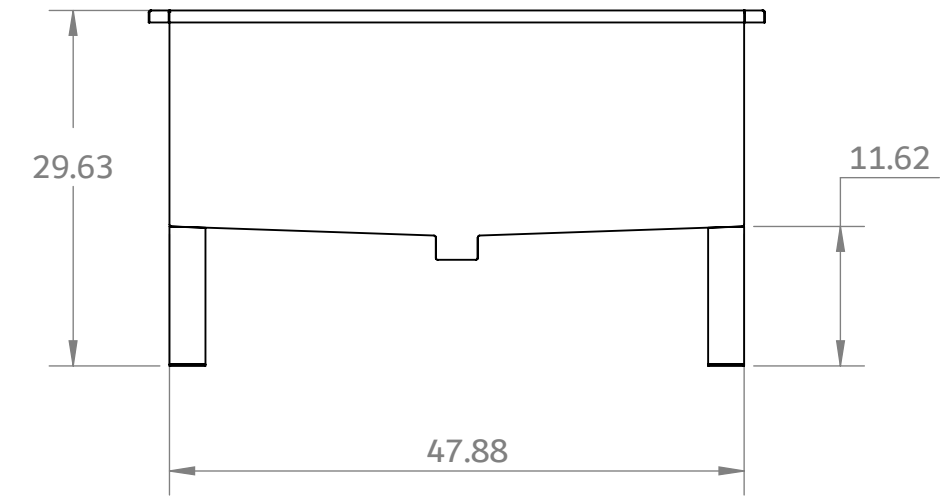

2

1

BEND RADIUS:	DRAWN BY:		
	DATE: 10/28/2021		
BEND DEDUCTION:	THICKNESS:	PART NUMBER:	
<small>UNLESS OTHERWISE SPECIFIED: DIMENSIONS ARE IN INCHES AND DEGREES</small>	MATERIAL: AISI 304	DESCRIPTION:	
TOLERANCES: FRACTIONAL: ± 1/32 ANGULAR: MACH ± 1/2" TWO PLACE DECIMAL: ± .015 THREE PLACE DECIMAL: ± .005	FINISH:	WEIGHT: 333.104	REV: A